

KRILNA BRZA PREPREKA

ŠIFRA PROIZVODA: DAS-Q70

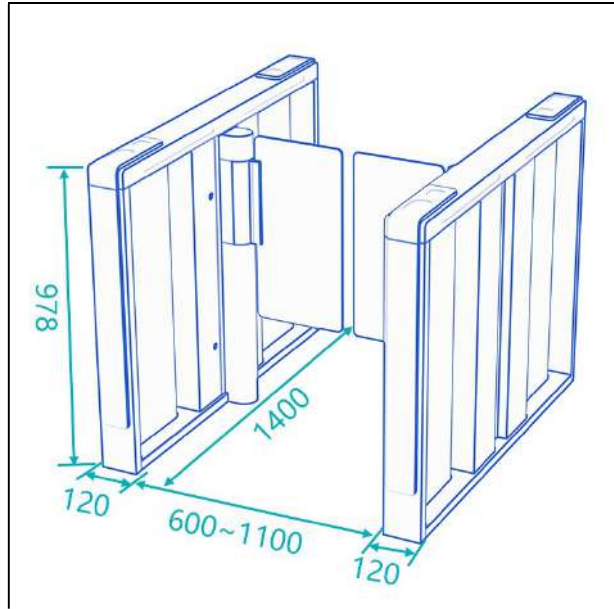

NIŽE U ORIGINALU

Features of Speed Gate

- Long-life performance, high operation dependability and fast response
- The whole system runs smoothly, low noise, no mechanical impact
- Single directional or Bi-directional is selectable
- Automatic reset function: swing arms will lock automatically within 5s (can be setting) if passenger delay to entry
- When power is off, swing arms will open automatically, which is complying with fire safety requirements
- LED indicator (red — means no entry; green → means entry)
- Infrared sensor alarm function, in case of illegal intrusion and reverse intrusion
- Anti-intrusion function, the turnstile is locked automatically until valid opening signal input
- Anti-reverse function, the turnstile alarms if someone wants to entry in the reverse direction
- Anti-trailing function, the turnstile alarm if someone wants to burst in without permission
- Glass arms will reset automatically if is off position after strong hit. The movement will not be broken or damaged for bump
- It has the fastest open and close speed rate, 0.2 second. The open and close speed rate can be adjusted
- Easy to install and maintain
- 3-year warranty support

Integrate Any Access Controllers

Model DAS-Q70 can be integrated with any 3rd access control systems, like card, QR/bar code, biometric, button, remote control, palm vein and so on.

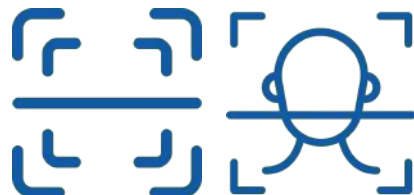

+381 11 355 7599
+381 63 598 017
office@aspekt.rs

Product Parameters

Model No.	DAS-Q70
Brand	Daosafe
Framework Material	Steel + White and black stoving varnish
Swipe Card Panel Material	Tempered glass
Arm Material	Plexiglas-transparency
Dimension	1400 *120 * 978mm
Weight	75kg/pcs
Passage Width	600~1100mm
Arm Height	900~1800mm
Passing Direction	Single directional / Bi-directional
MCBF	15 million
Power Supply	AC220V/110V, 50/60Hz
Operation Voltage	24V DC
Power Consumption	20W
Operation Temperature	-20 °C - 75 °C
Operation Humidity	0 ~ 95% (No freeze)
Working Environment	Indoor / Outdoor
Flow Rate	45 people per minute
Infrared Sensor	6 Pairs (standard)
LED Indicator	Yes
Emergency	Arms will open automatically
Communication	Dry contact, Relay signal, RS485

KRAJ



+381 11 355 7599
+381 63 598 017
office@aspekt.rs