

TROKRAKA ROTACIONA PREPREKA

ŠIFRA PROIZVODA: DAS-Q10

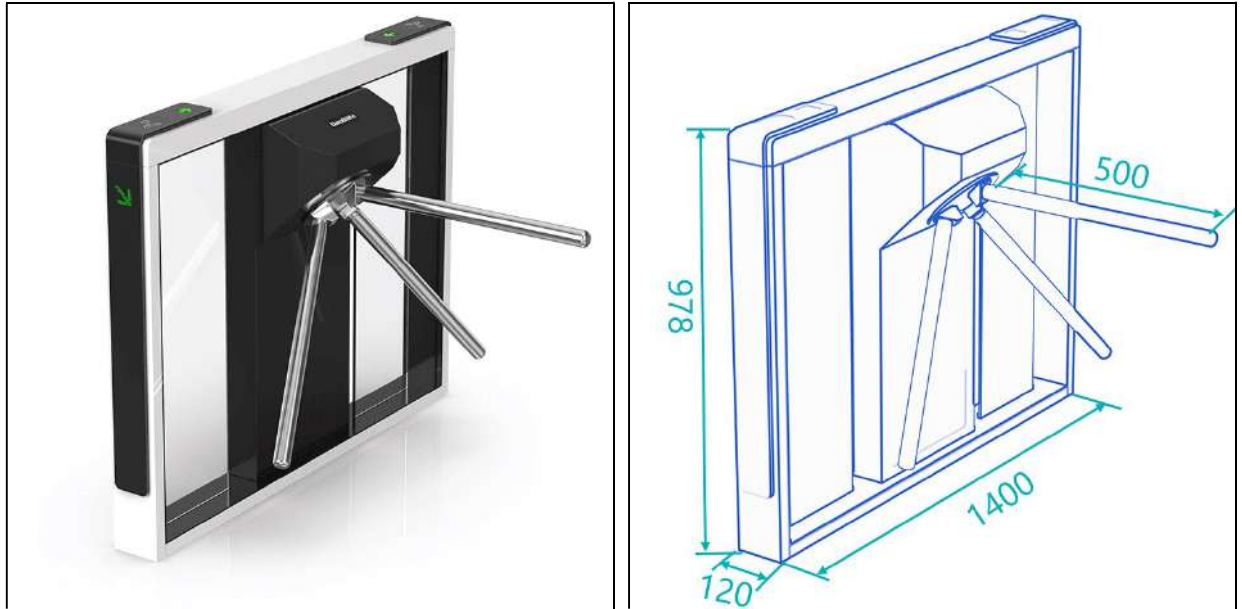

NIŽE U ORIGINALU

- Long-life performance, high operation dependability and fast response
- The whole system runs smoothly, low noise, no mechanical impact
- Single directional or bi-directional is selectable
- Automatic reset function: swing arms will lock automatically within 5s (can be setting) if passenger delay to entry
- When power is off, arms will drop down automatically, which is complying with fire safety requirements
- LED indicator (red means no entry; green means entry)
- Only one person can pass at one time, to prevent the illegal following
- Easy to install and maintain
- 3-year warranty support

Product Details and Dimensions

All the details and dimensions can be customized according to your project site

Integrate Any Access Controllers

Model DAS-Q50 can be integrated with any 3rd access control systems, like card, QR/bar code, biometric, button, remote control, palm vein and so on.



+381 11 355 7599
+381 63 598 017
office@aspekt.rs

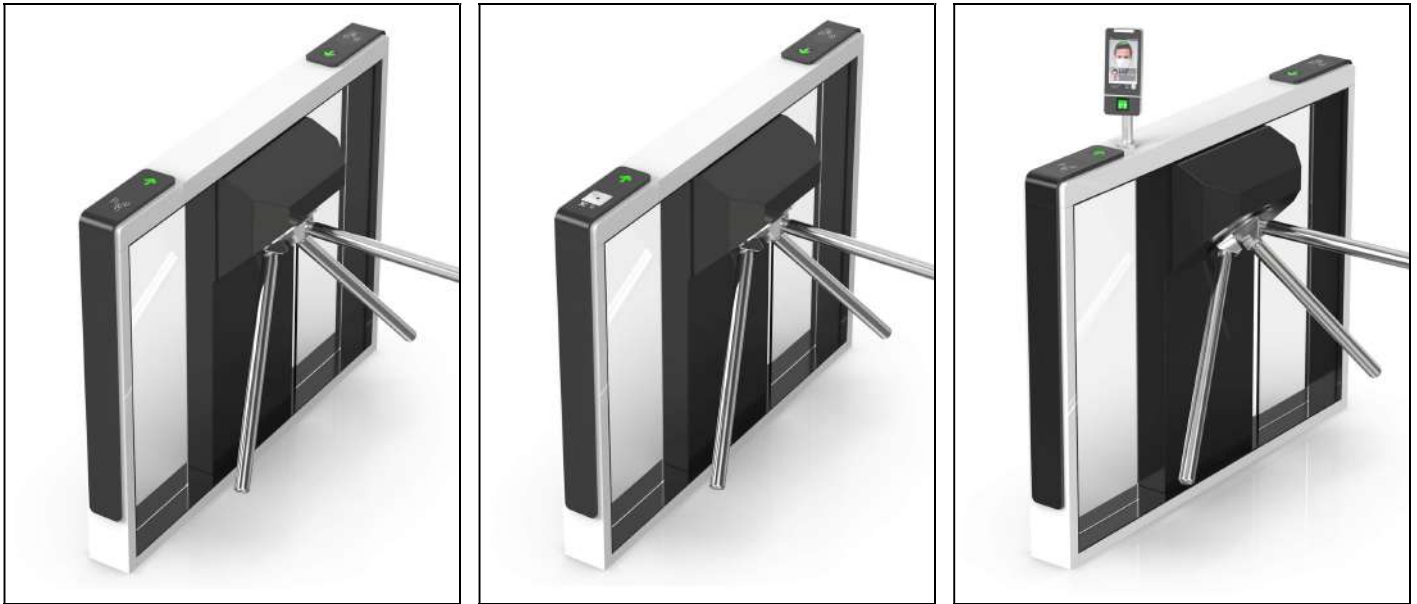

Product Parameters

Model No.	DAS-Q10
Framework Material	Steel + White and black storing varnish
Swipe Card Panel Material	Tempered glass
Arm Material	304 Stainless Steel
Dimension	1400 *120 * 978mm
Weight	75kg/pcs
Passage Width	550mm (Arm length: 500mm)
Passing Direction	Single directional / Bi-directional
MCBF	10 million
Power Supply	AC220V/110V, 50/60Hz
Operation Voltage	24V DC
Power Consumption	20W
Operation Temperature	-20 °C - 75 °C
Operation Humidity	0 ~ 95% (No freeze)
Working Environment	Indoor / Outdoor
Flow Rate	35 people per minute
LED Indicator	Yes
Emergency	Arms will drop down automatically
Communication	Dry contact, Relay signal, RS485

KRAJ



+381 11 355 7599
+381 63 598 017
office@aspekt.rs