

# TROKRAKA ROTACIONA PREPREKA

ŠIFRA PROIZVODA: **DAS5000**

Namenjena pre svega kontroli pristupa putnika u autobuse, vozove itd.

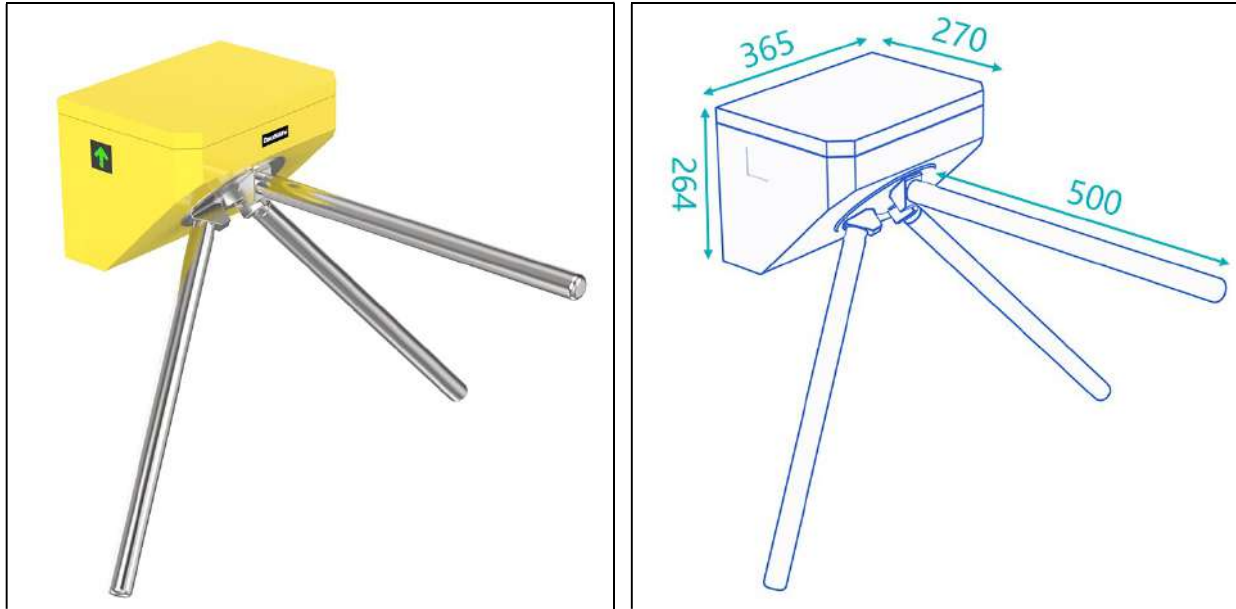

## NIŽE U ORIGINALU

### Features of Bus Turnstile

- Long-life performance, high operation dependability and fast response
- The whole system runs smoothly, low noise, no mechanical impact
- Single directional or Bi-directional is selectable
- Automatic reset function: turnstile arm will lock automatically within 5s (can be setting) if passenger delay to entry
- Anti-tailing function: only one person passes at one time
- When power is off, arms will open automatically, which is complying with fire safety requirements
- LED indicator (red x means no entry; green → means entry)
- Easy to install and maintain
- 3-year warranty support

### Product Parameters

Model No.	DS5000
Framework Material	Steel + Yellow stoving varnish
Color	Yellow (default), other colors (optional)
Dimension	270 * 365 * 264mm
<b>Weight</b>	<b>25kg/pcs</b>
Passage Width	550mm
Passing Direction	Single directional / Bi-directional
<b>MCBF</b>	<b>10 million</b>
Power Supply	AC220V±10%, 50Hz
Operation Voltage	24V DC

Power Consumption	40W
Operation Temperature	-20°C ~ 75°C (below -20°C can be customized)
Operation Humidity	0 ~ 95% (No freeze)
<b>Working Environment</b>	<b>Indoor / Outdoor with solid rain protection roof</b>
Flow Rate	35 people per minute
Emergency	Automatic arm open when power off
Communication	Dry contact, Relay signal, RS485

**KRAJ**

+381 11 355 7599  
+381 63 598 017  
office@aspekt.rs